

Operator's Manual

CRAFTSMAN[®] 15" VARIABLE SPEED FLOOR MODEL DRILL PRESS

Model No.
351.229350

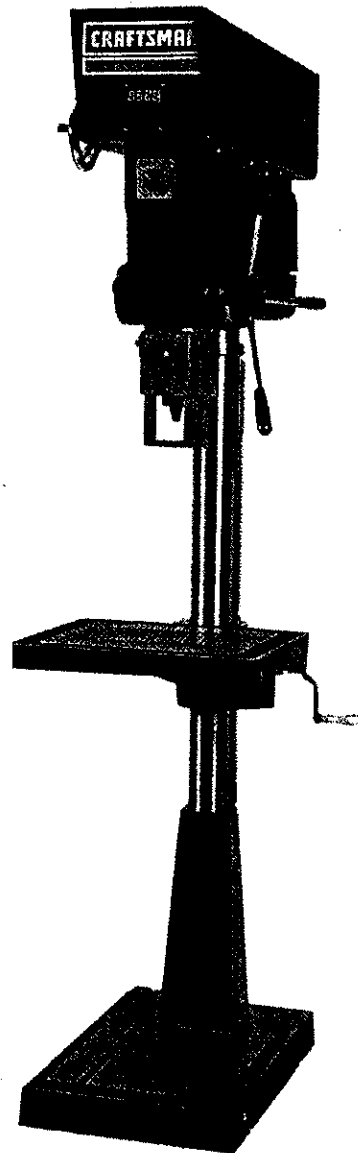

CAUTION: Read and follow all Safety Rules and Operating Instructions before First Use of this Product.

Sears, Roebuck and Co., Hoffman Estates, IL 60179 U.S.A.

16314.00 Draft (01/03/00)

SAFETY

ASSEMBLY

OPERATION

MAINTENANCE

FAULTS

TABLE OF CONTENTS

Warranty	2
Safety Rules	2-3
Unpacking	3
Assembly	3
Installation	3-5
Operation	5-6
Maintenance	6-7
Troubleshooting	8
Parts Illustration and List	9-15

WARRANTY

FULL ONE YEAR WARRANTY

If this product fails due to a defect in material or workmanship within one year from the date of purchase, Sears will at its option repair or replace it free of charge.

Contact your nearest Sears Service Center to arrange for product repair, or return this product to place of purchase for replacement.

If this product is used for commercial or rental purposes, this warranty will apply for 90 days from the date of purchase.

This warranty gives you specific legal rights and you may also have other rights which vary from state to state.

Sears, Roebuck and Co., Dept. 817WA, Hoffman Estates, IL 60179

SAFETY RULES

WARNING: For your own safety read all of the instructions and precautions before operating tool.

CAUTION: Always follow proper operating procedures as defined in this manual even if you are familiar with use of this or similar tools. Remember that being careless for even a fraction of a second can result in severe personal injury.

BE PREPARED FOR JOB

- Wear proper apparel. Do not wear loose clothing, gloves, neckties, rings, bracelets or other jewelry which may get caught in moving parts of machine.
- Wear protective hair covering to contain long hair.
- Wear safety shoes with non-slip soles.
- Wear safety glasses complying with United States ANSI Z87.1. Everyday glasses have only impact resistant lenses. They are **NOT** safety glasses.
- Wear face mask or dust mask if operation is dusty.
- Be alert and think clearly. Never operate power tools when tired, intoxicated or when taking medications that cause drowsiness.

PREPARE WORK AREA FOR JOB

- Keep work area clean. Cluttered work areas invite accidents.
- Do not use power tools in dangerous environments.
- Do not use power tools in damp or wet locations. Do not expose power tools to rain.
- Work area should be properly lighted.
- Proper electrical receptacle should be available for tool. Three prong plug should be plugged directly into properly grounded, three-prong receptacle.
- Extension cords should have a grounding prong and the three wires of the extension cord should be of the correct gauge.
- Keep visitors at a safe distance from work area.
- Keep children out of workplace. Make workshop child-proof. Use padlocks, master switches or remove switch keys to prevent any unintentional use of power tools.

TOOL SHOULD BE MAINTAINED

- Always unplug tool prior to inspection.
- Consult manual for specific maintaining and adjusting procedures.
- Keep tool lubricated and clean for safest operation.
- Remove adjusting tools. Form habit of checking to see that adjusting tools are removed before switching machine on.
- Keep all parts in working order. Check to determine that the guard or other parts will operate properly and perform their intended function.
- Check for damaged parts. Check for alignment of moving parts, binding, breakage, mounting and any other condition that may affect a tool's operation.
- A guard or other part that is damaged should be properly repaired or replaced. Do not perform makeshift repairs. (Use parts list provided to order replacement parts.)

KNOW HOW TO USE TOOL

- Use right tool for job. Do not force tool or attachment to do a job for which it was not designed.
- Disconnect tool when changing accessories, such as bits, cutters and the like.
- Avoid accidental start-up. Make sure that the switch is in the OFF position before plugging in.
- Do not force tool. It will work most efficiently at the rate for which it was designed.
- Keep hands away from moving parts and cutting surfaces.
- Never leave tool running unattended. Turn the power off and do not leave tool until it comes to a complete stop.
- Do not overreach. Keep proper footing and balance.
- Never stand on tool. Serious injury could occur if tool is tipped or if blade is unintentionally contacted.

- Know your tool. Learn the tool's operation, application and specific limitations.
- Use recommended accessories (refer to page 13). Use of improper accessories may cause risk of injury to persons.
- Handle workpiece correctly. Secure work with clamps or vise. Leave hands free to operate machine. Protect hands from possible injury.
- Feed work into a bit or cutter against the direction of rotation of bit or cutter.
- Turn machine off if it jams. A cutter jams when it digs too deeply into the workpiece. (The motor force keeps it stuck in workpiece.)

CAUTION: Think safety! Safety is a combination of operator common sense and alertness at all times when tool is being used.

WARNING: Do not attempt to operate tool until it is completely assembled according to the instructions.

UNPACKING

Refer to Figures 4 and 6.

CAUTION: Be careful not to touch overhead power lines, piping, lighting, etc., if lifting equipment is used. Drill press weighs approximately 450 lbs. Proper tools, equipment and qualified personnel should be employed in all phases of unpacking and installation.

Crates should be handled with care to avoid damage from dropping, bumping, etc. Store and unpack crates with correct side up. After uncrating drill press, inspect carefully for any damage that may have occurred, during transit. Check for loose, missing or damaged parts. If any damage or loss has occurred, claim must be filed with carrier immediately. Check for completeness. Immediately report missing parts to dealer.

Drill press is shipped assembled, except for the drill chuck with key, arbor and guard.

IMPORTANT: The tool has been coated with a protective coating. In order to ensure proper fit and operation, the coating must be removed. Remove coating with mild solvents, such as mineral spirits and a soft cloth. Nonflammable solvents are recommended. After cleaning, cover all exposed surfaces with a light coating of oil. Paste wax is recommended for table top.

NOTE: Never use highly volatile solvents. Avoid getting cleaning solution on paint as it may tend to deteriorate these finishes. Use soap and water on painted components.

ASSEMBLY

Refer to Figures 4, 6 and 7.

MOUNT DRILL CHUCK AND ARBOR

- Be sure spindle taper, arbor taper and chuck taper are clean and dry.

- Insert arbor into spindle, push arbor into spindle and twist arbor slightly to release air trapped in taper.
- Mount chuck onto arbor, push chuck over arbor and twist arbor slightly to release air trapped in taper.
- Be sure chuck and arbor are securely mounted.

MOUNT DRILL PRESS GUARD

Refer to Figure 4.

Place clamp opening over bottom of drill press quill and secure by tightening socket head bolt at rear of clamp (Key. No. 1).

CAUTION: The operation of any power tool can result in foreign objects being thrown into the eyes, which can result in severe eye damage. Always wear safety glasses complying with United States ANSI Z87.1 (shown on package) before commencing power tool operation. Safety glasses are available through your Grainger catalog.

TABLE CRANK

Refer to Figure 7.

- Remove handle from inside of crank arm.
- Thread handle onto outside of crank arm (Key. Nos. 15 and 16).

INSTALLATION

MOUNT DRILL PRESS

- Drill press must be mounted to flat level surface. Use shims or machine mounts if necessary. Do not mount drill press in direct sunlight.
- Be sure to bolt drill press to floor securely to prevent tipping and minimize vibration.
- Tighten all nuts and bolts that may have loosened during shipment.

POWER SOURCE

WARNING: Do not connect drill press to the power source until all assembly steps have been completed.

The motor is designed for operation on the voltage and frequency specified. Normal loads will be handled safely on voltages not more than 10% above or below specified voltage. Running the unit on voltages which are not within range may cause overheating and motor burn-out. Heavy loads require that voltage at motor terminals be no less than the voltage specified on nameplate.

- Drill press requires a 115/230 volt, 60 Hz power source.
- To use the drill press with a 230V power supply, have a qualified electrician attach a 230 volt, 20/30A three-prong plug (not supplied) onto drill press line cord.
- Power supply to the motor is controlled by a rotary switch.

GROUNDING INSTRUCTIONS

WARNING: Improper connection of equipment grounding conductor can result in the risk of electrical shock. Equipment should be grounded while in use to protect operator from electrical shock.

- Check with a qualified electrician if you do not understand grounding instructions or if you are in doubt as to whether the tool is properly grounded.
- This tool is equipped with an approved 3-conductor cord rated up to 240V and a 3-prong grounding type plug rated at 115V (See Figure 1) for your protection against shock hazards.
- Grounding plug should be plugged directly into a properly installed and grounded 3-prong grounding-type receptacle, as shown (See Figure 1).

NOTE: If the unit is operated at 230V, a 230V plug (not supplied) must be used.

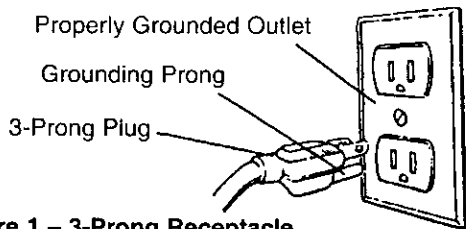

Figure 1 – 3-Prong Receptacle

- Do not remove or alter grounding prong in any manner. In the event of a malfunction or breakdown, grounding provides a path of least resistance for electrical shock.

WARNING: Do not permit fingers to touch the terminals of plug when installing or removing from outlet.

- Plug must be plugged into matching outlet that is properly installed and grounded in accordance with all local codes and ordinances. Do not modify plug provided. If it will not fit in outlet, have proper outlet installed by a qualified electrician.
- Inspect tool cords periodically, and if damaged, have repaired by an authorized service facility.
- Green (or green and yellow) conductor in cord is the grounding wire. If repair or replacement of the electric cord or plug is necessary, do not connect the green (or green and yellow) wire to a live terminal.
- Where a 2-prong wall receptacle is encountered, it must be replaced with a properly grounded 3-prong receptacle installed in accordance with National Electric Code and local codes and ordinances.

WARNING: Any receptacle replacement should be performed by a qualified electrician.

A temporary 3-prong to 2-prong grounding adapter (See Figure 2) is available for connecting plugs to a two pole outlet if it is properly grounded.

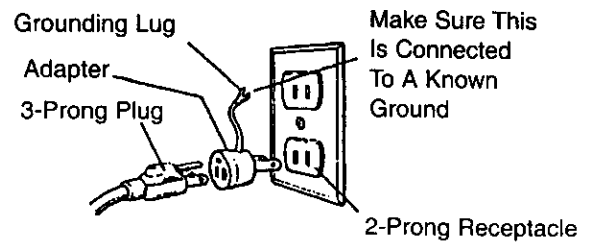

Figure 2 – 2-Prong Receptacle with Adapter

- Do not use a 3-prong to 2-prong grounding adapter unless permitted by local and national codes and ordinances. (A 3-prong to 2-prong grounding adapter is not permitted in Canada.)
- Where a 3-prong to 2-prong grounding adapter is permitted, the rigid green tab or terminal on the side of the adapter must be securely connected to a permanent electrical ground such as a properly grounded water pipe, a properly grounded outlet box or a properly grounded wire system.
- Many cover plate screws, water pipes and outlet boxes are not properly grounded. To ensure proper ground, grounding means must be tested by a qualified electrician.

EXTENSION CORDS

- The use of any extension cord will cause some drop in voltage and loss of power.
- Wires of the extension cord must be of sufficient size to carry the current and maintain adequate voltage.
- Use the table to determine the minimum wire size (A.W.G.) extension cord.
- Use only 3-wire extension cords having 3-prong grounding type plugs and 3-pole receptacles which accept the tool plug.
- If the extension cord is worn, cut or damaged in any way, replace it immediately.

EXTENSION CORD LENGTH

Wire Size	A.W.G.
Up to 25 ft.	14

NOTE: Using extension cords over 25 ft. long is not recommended.

MOTOR

Drill press is supplied with a 2 HP (max developed) motor.

The 120 Volt AC universal motor has the following specifications:

Horsepower (Maximum Developed)	2
Voltage	115/230
Amperes	14/7
Hertz	60
Phase	Single
RPM	1150

ELECTRICAL CONNECTIONS

WARNING: All electrical connections must be performed by a qualified electrician. Make sure unit is off and disconnected from power source while motor is mounted, connected, reconnected or anytime wiring is inspected.

- Drill press motor can be wired for 115 or 230 volts, single-phase operations.
- Motor must rotate in clockwise direction facing shaft end of motor
- See wiring diagram (Figure 3) for wiring instructions, single-phase operation.

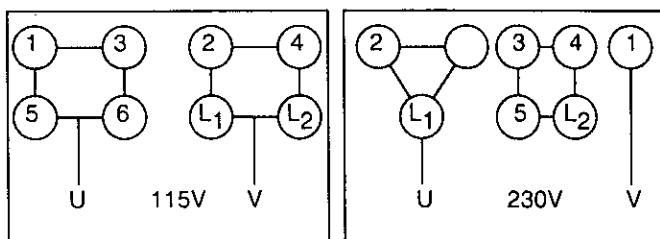

1, 2, 3, 4, 5, 6 - Motor Leads
L1, L2 - Digital Readout Leads
U, V - Power Supply

Figure 3 – Motor and Digital Readout Wiring Diagram

OPERATION

DESCRIPTION

Craftsman 15" Variable Speed Professional Drill Press features a fine grain cast iron base, table and head. Spindle speeds are infinitely variable from 300 to 3300 RPM. Drill press includes arbor with Jacob taper #6, chuck with key and drill press guard. Spindle travels 5" and has scale and depth control.

Large 12 $\frac{1}{8}$ " x 16" table rotates around column. Table surface is precision ground and features T-slots, water trough and easy height adjustment to handle most drilling operations. 1 HP motor can be wired for 115 or 230 volt operation.

SPECIFICATIONS

Infinitely Variable Speed	300-3300 RPM
Table size	12 $\frac{1}{8}$ " x 16"
T-slots	2 each, $\frac{5}{8}$ "
Swing	15"
Arbor taper	Jacob taper #6
Quill diameter	2.16"
Spindle diameter	1.74"
Maximum distance table to spindle	25 $\frac{1}{2}$ "
Overall height	70 $\frac{1}{4}$ "
Shipping weight	450 lb

OPERATION SAFETY RULES

WARNING: For your own safety, read all of the instructions and safety precautions before operating drill press.

WARNING: Operation of any power tool can result in foreign objects being thrown into eyes which can result in severe eye damage. Always wear safety goggles complying with United States ANSI Z87.1 (shown on package) before commencing power tool operation.

- Know general power tool safety. Make sure all precautions are understood (see pages 2, 3, and 5).
- Always wear eye protection or face shield.
- Do not wear loose clothing, gloves, neckties, rings, bracelets or other jewelry.
- Whenever adjusting or replacing any parts on drill press, turn switch off and remove plug from power source.
- Make sure all moving parts are free from interference.
- When drilling in material that causes dust, a dust mask shall be worn.
- Non-slip footwear and safety shoes are recommended.
- Do not plug in drill press unless switch is in "off" position. After turning switch on, allow drill press to come to full speed before operating.
- Keep hands clear of all moving parts.
- Use recommended speed for drill accessory and workpiece material.
- Drill press head and table shall be securely locked to column before operating drill press. This must always be checked prior to starting machine.
- Secure workpiece using either clamps or a vise to drill press table.
- Never brush away any chips while machine is in operation. All clean up should be done when machine is stopped.
- Make sure the machine is securely mounted to floor.
- Make sure drill bits are properly secured.
- Make sure drills are sharp.
- Disconnect power when changing bits.
- Keep lightly lubricated as directed.
- Always keep hands and fingers clear of the descending head and the turning bit.
- Make sure all included covers and guards are in place and secured before operating the drill press.
- Do not leave drill press running when it is unattended.
- Keep children away from the drill press at all times.
- Do not operate drill press when you are tired, ill or on medications that affect your emotional or physical stability.
- Turn switch off and disconnect power whenever drill press is not in use.
- Keep drill press maintained. Follow maintenance instructions (see pages 6 and 7).

SPEED ADJUSTMENT

WARNING: Be sure motor is running when adjusting spindle speed. Damage to drill press may result if spindle speed is adjusted when motor is at rest.

Refer to Figure 5.

- Spindle speed is read from digital readout (Key. No. 2) located on front of drill press.
- Spindle speed can be adjusted only when the motor is running.
- Turn on the drill press. Rotate speed change hand-wheel (Key. No. 22) until readout indicates the desired spindle speed. (Speeds on readout represent spindle RPM.)

TABLE ADJUSTMENT

Refer to Figure 7.

- Table can be raised and lowered on column and can also be rotated about the column.
- To raise table, loosen table lock handle (Key. No. 23), rotate crank arm handle (Key. No. 15) until table is in desired position. Be sure to secure table position by tightening table lock handle.
- To rotate table about column, loosen table lock handle and rotate table to desired position. Be sure to secure table position by tightening table lock handle.

HEAD ADJUSTMENT

Refer to Figure 6.

To rotate head about column, loosen head locking handle (Key. No. 44) and rotate head to desired position. Be sure to secure head position by tightening head locking handle.

DEPTH STOP ADJUSTMENT

Refer to Figure 6.

- To control drilling depth, loosen locking knob (Key. No. 12) inside feed handle hub (Key. No. 11). Rotate graduated collar (Key. No. 8) so desired depth is indicated on collar next to the indicator line. Tighten the locking knob. Use this feature to drill more than one hole to the same depth.
- Spindle can be locked in either fully or partially down position. Loosen locking knob (Key. No. 12). Lower chuck to the desired depth, rotate graduated collar (Key. No. 8) fully clockwise and tighten the locking knob. Use this feature to set up and align work.

GUARD ADJUSTMENT

Refer to Figure 4.

- Lower guard will automatically slide into upper guard as drill press is operated. Be sure lower guard slides smoothly in and out of upper guard
- Lower guard position can be locked by tightening adjustment knob (Key. No. 4) with lower guard in desired position.
- Upper and lower guard assembly can be flipped up out of the way for easy cutting bit changes.

- Pull plunger pin out and pivot guard assembly up. After changing bit and before operating drill press, be sure to flip guard assembly down with plunger seated securely in clamp.

MOUNT DRILL BIT

WARNING: Be sure drill press is turned off and is disconnected from power source before adjusting speeds.

- Place drill bit in jaws of drill chuck.
- Tighten chuck with drill chuck key. Be sure to tighten the chuck using all three key positions on the chuck body and remove chuck key.

MAINTENANCE

WARNING: Turn the switch "off" and unplug drill press from power source before maintaining or lubricating drill press.

LUBRICATION

Refer to Figures 5, 6 and 7.

Keep quill and column lubricated with light oil or lubricant such as WD-40. Use 20 wt. non-detergent oil for oil lubrication. Use a general purpose grease for grease lubrication.

MONTHLY

- Spindle splines: lower quill assembly and pour 6-8 drops of oil into hole in center of cap (Figure 5, Key. No. 32).
- Speed change fork: oil speed change fork and link (Figure 5, Key. Nos. 15 and 16) through hole in fork.
- Quill rack: lower quill assembly and oil rack (or gear teeth) on back of quill. (Figure 6, Key. No. 23). Raise and lower quill several times to spread oil across rack.
- Rack: oil teeth evenly or rack (Figure 7, Key. No. 6).

YEARLY

Gearbox: remove gear box cover (Figure 5, Key. No. 18) and remove old grease. Repack gear box with grease and replace gear box cover.

REPLACE WORN VARIABLE SPEED BELT

NOTE: Lower motor pulley is spring loaded. Take care not to pinch fingers between pulleys or between pulley and belt.

Refer to Figure 5.

- Set drill press at lowest speed while motor is running.
- Turn drill press off and disconnect from power source.
- Remove socket head bolt and handwheel (Key. Nos. 21 and 22).
- Remove flat head screws and plastic cover (Key. Nos. 3 and 4).
- Remove socket head bolts and pulley cover (Key. Nos. 7 and 1).

- Loosen hex nuts (Key. No. 56) on hex head bolts (Key. No. 64). Pivot motor mount plate (Key. No. 63) towards head.
- Slip variable speed belt (Key. No. 46) off spindle pulleys (Key. Nos. 34 and 35).
- Remove belt from motor pulleys. The lower motor pulley (Key. No. 50) may need to be pushed down to remove belt.
- Slide new belt between upper and lower motor pulleys (Key. Nos. 49 and 50).
- Slide lower motor pulley down and place belt between pulleys as close to motor shaft as possible.
- Slide belt between spindle pulleys on one side.
- Rotate upper spindle pulley and belt by hand to slide

belt between pulleys. Be careful not to pinch fingers between pulley and belt.

- Pivot motor away from head and secure position with hex nuts.
- Replace pulley cover, plastic cover and handwheel.
- Rotate speed change handwheel firmly counter-clockwise until resistance is felt.

CLEAN MOTOR

Frequently blow out any dust that may accumulate inside motor. If power cord is worn, cut or damaged in any way, have it replaced immediately. For motor lubrication, follow instructions on motor plate.

TROUBLESHOOTING

SYMPTOM	POSSIBLE CAUSE(S)	CORRECTIVE ACTION
Spindle does not turn	<ol style="list-style-type: none"> 1. No power to drill press 2. Defective switch 3. Defective motor 	<ol style="list-style-type: none"> 1. Check wiring, fuse or circuit breaker 2. Replace switch 3. Replace motor
Noisy spindle	Defective bearings	Replace bearings
Noisy operation	<ol style="list-style-type: none"> 1. Worn variable speed belt 2. Dry spindle 3. Loose pulley 	<ol style="list-style-type: none"> 1. Replace belt, See Replace Worn Variable Speed Belt, page ? 2. Lubricate spindle, See Lubrication, page ? 3. Check motor pulleys; tighten as necessary
Excessive spindle runout	Worn or defective bearings	Replace bearings
Drilled holes not round	<ol style="list-style-type: none"> 1. Improper mounting of drill bit, chuck or arbor 2. Worn or broken bit 3. Speed or feed too fast 4. Workpiece drilling needs lubrication 	<ol style="list-style-type: none"> 1. Mount properly 2. Replace bit 3. Reduce speed or feed as needed 4. Use cutting fluid

Model 351.229350

Figure 4 - Replacement Parts Illustration for Guard

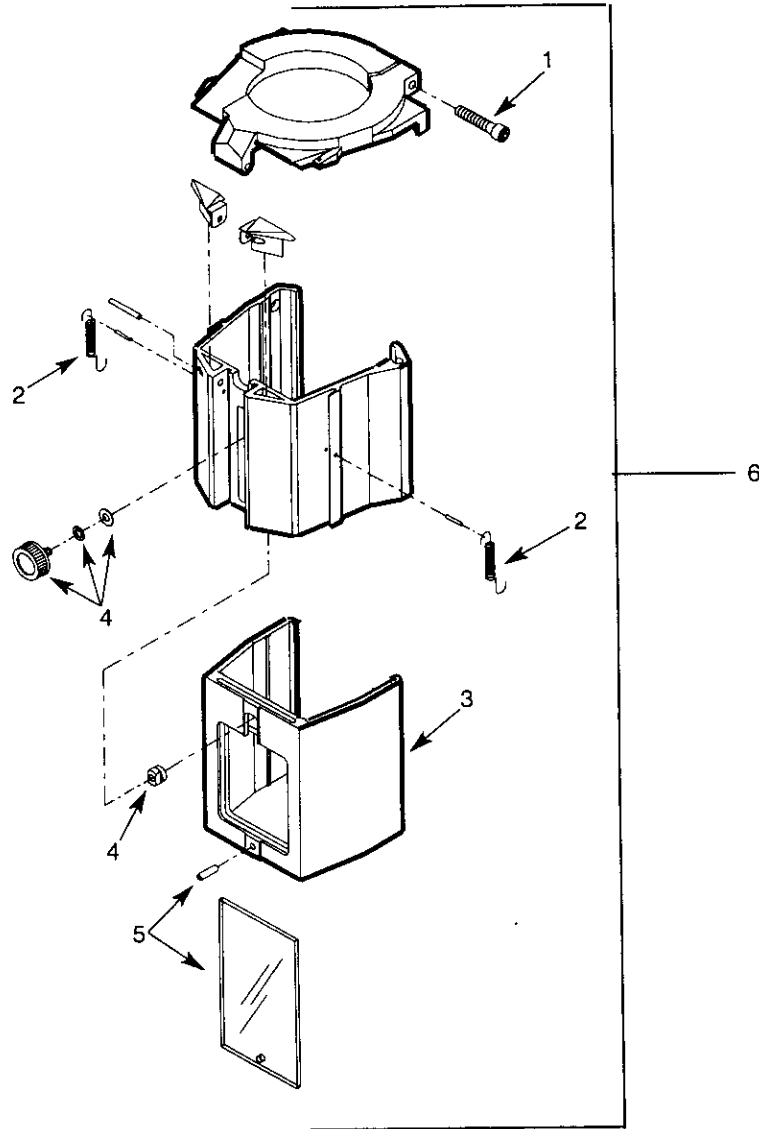

REPLACEMENT PARTS LIST FOR GUARD

KEY NO.	PART NO.	DESCRIPTION	QTY.
1	02580.00	1/4-20 x 1 1/2" Socket Head Bolt	1
2	08431.00	Spring (set of 2)	1
3	08432.00	Lower Guard	1
4	08433.00	Adjustment Knob Assembly	1
5	08434.00	Shield with Mounting Pin	1
6	08912.00	Guard (Key Nos. 1-5)	1

* Standard hardware item available locally.

TANDEM

Model 351.229350

Figure 5 - Replacement Parts Illustration for Head

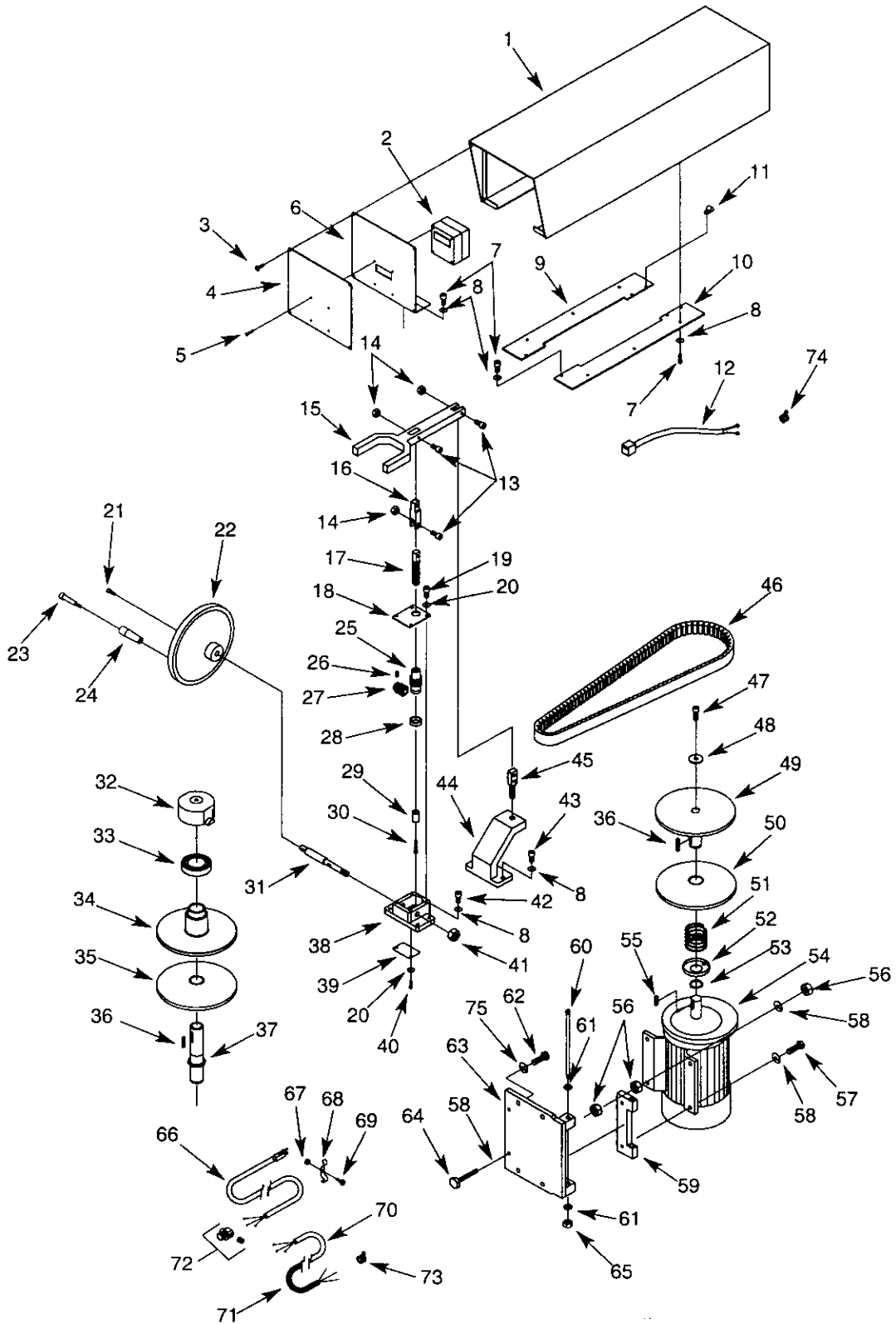

REPLACEMENT PARTS LIST FOR HEAD

KEY NO.	PART NO.	DESCRIPTION	QTY.
1	15840.00	Pulley Cover	1
2	15841.00	Digital Readout with Screws	1
3	05318.00	5-0.8 x 12mm Flat Head Screw	4
4	15171.00	Cover	1
5	16422.00	#6-24 x 3/8" Thread Forming Screw	4
6	15842.00	Front Cover	1
7	03806.00	6-1.0 x 10mm Socket Head Bolt	14
8	STD851006	6mm Flat Washer*	16
9	15843.00	Left Plate	1
10	15844.00	Right Plate	1
11	15135.00	Clamp	2
12	16019.00	Readout Cord	1
13	09732.00	8-1.25 x 35mm Socket Head Bolt	3
14	08529.00	8-1.25mm Fiber Hex Nut	3
15	15845.00	Fork	1
16	15846.00	Link	1
17	15847.00	Threaded Link	1
18	15848.00	Plate	1
19	00814.00	5-0.8 x 16mm Socket Head Bolt	4
20	STD851005	5mm Flat Washer*	6
21	01760.00	6-1.0 x 16mm Socket Head Bolt	1
22	15849.00	Handwheel	1
23	15174.00	Shoulder Bolt	1
24	15175.00	Handle	1
25	15176.00	Worm Gear	
26	16423.00	5-0.8 x 4mm Set Screw	2
27	15177.00	Worm	1
28	15178.00	Bushing	1
29	15179.00	Bushing	1
30	05284.00	5-0.8 x 25mm Socket Head Bolt	1
31	15180.00	Shaft	1
32	15181.00	Cap	1
33	16424.00	6008ZZ Bearing	1
34	15182.00	Upper Spindle Pulley	1
35	15183.00	Lower Spindle Pulley	1
36	16303.00	5 x 5 x 16mm Key	2
37	15127.00	Spindle Shaft	1

KEY NO.	PART NO.	DESCRIPTION	QTY.
38	15184.00	Gear Box	1
39	16000.00	Bottom Plate	1
40	05331.00	5-0.8 x 12mm Socket Head Bolt	2
41	05358.00	12-1.75mm Fiber Hex Nut	1
42	00179.00	6-1.0 x 20mm Socket Head Bolt	2
43	06182.00	6-1.0 x 30mm Socket Head Bolt	2
44	16001.00	Bracket	1
45	16002.00	Threaded Link	1
46	16003.00	Variable Speed Belt	1
47	16004.00	8-1.25 x 30mm Hex Flange Bolt	1
48	16005.00	12 x 30 x 2mm Spacer	1
49	16006.00	Upper Motor Pulley	1
50	16007.00	Lower Motor Pulley	1
51	16008.00	Spring	1
52	16009.00	Spring Cap	1
53	01022.00	3AMI-28 Retaining Ring	1
54	16010.00	Motor	1
55	07885.00	5 x 5 x 40mm Key	1
56	STD840812	8-1.25mm Hex Nut*	6
57	00865.00	8-1.25 x 20mm Hex Head Bolt	2
58	STD852008	8mm Lock Washer*	4
59	16011.00	Bracket	1
60	16012.00	3/8"-16 x 9" Hex Head Bolt	1
61	STD551137	3/8" Lock Washer*	2
62	STD836020	10-1.5 X 20mm Hex Head Bolt*	4
63	16013.00	Motor Mount Plate	1
64	STD835050	8-1.25 x 50mm Hex Head Bolt*	2
65	STD541037	3/8"-16 Hex Nut*	1
66	07860.01	Line Cord	1
67	STD541010	#10-24" Hex Nut	1
68	16014.00	Cord Clamp	1
69	STD11003	#10-24 x 3/8" Pan Head Screw*	1
70	16015.00	Motor Cord	1
71	07862.02	Motor Cord Cover	1
72	07863.00	Strain Relief	1
73	02434.00	Strain Relief	1
74	01413.00	Strain Relief	1
75	STD852010	10mm Lock Washer*	4
Δ	16314.00	Operator's Manual	1

* Standard hardware item available locally.

Δ Not Shown

Model 351.229350

Figure 6 - Replacement Parts Illustration for Lower Head Components

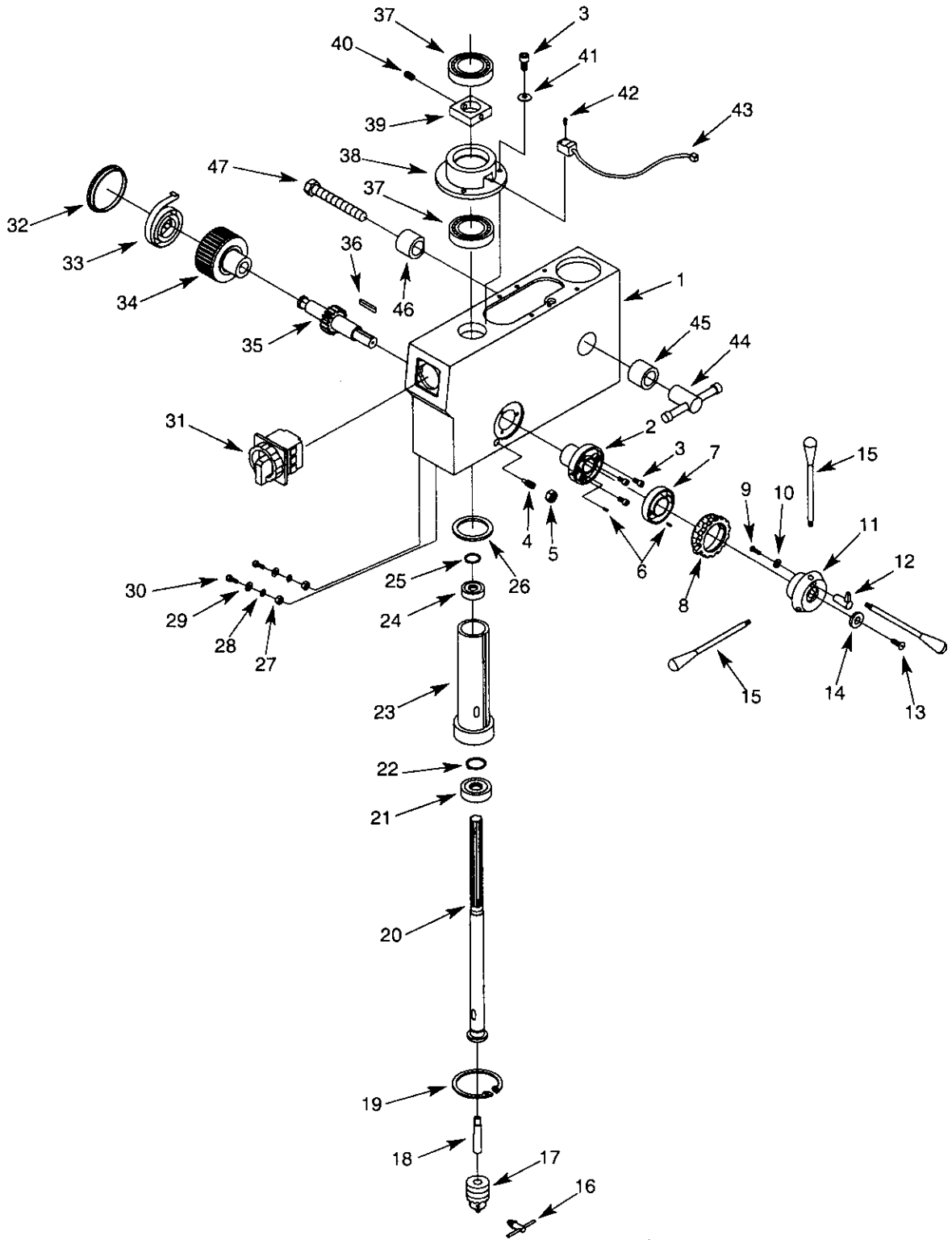

REPLACEMENT PARTS LIST FOR LOWER HEAD COMPONENTS

KEY NO.	PART NO.	DESCRIPTION	QTY.
1	16016.00	Head	1
2	07826.01	Flange	1
3	01760.00	6-1.0 x 16mm Socket Head Bolt	6
4	02576.00	10-1.5 x 40mm Dog Point Set Screw	1
5	STD841015	10-1.5mm Hex Nut*	1
6	16017.00	4 x 15mm Dowel Pin	2
7	07828.00	Collar	1
8	07829.00	Graduated Collar	1
9	01323.00	6-1.0 x 30mm Hex Head Bolt	1
10	07835.00	Square Washer	1
11	07830.00	Feed Handle Hub	1
12	07834.01	Lock Knob	1
13	07832.00	6-1.0 x 16mm Flat Head Screw	1
14	07833.00	6 x 32 x 5mm Spacer	1
15	07831.00	Feed Handle with Knob	3
16	00501.00	Chuck Key	1
17	07845.00	Chuck with Key (Key No. 16)	1
18	07936.00	MT3/JT6 Arbor	1
19	08922.00	3BMI-72 Retaining Ring	1
20	07842.01	Spindle	1
21	02627.00	6207ZZ Bearing	1
22	08924.00	3AMI-35 Retaining Ring	1
23	07841.01	Quill	1

KEY NO.	PART NO.	DESCRIPTION	QTY.
24	00989.00	6204ZZ Bearing	1
25	00256.00	3AMI-20 Retaining Ring	1
26	08641.00	Rubber Ring	1
27	STD541010	#10-24 Hex Nut*	2
28	01474.00	#10 Serrated Washer	2
29	STD551010	#10 Flat Washer*	2
30	STD511007	#10-24 x 3/4" Pan Head Screw*	2
31	16018.00	Switch	1
32	07821.00	Spring Cover	1
33	07822.00	Spring	1
34	07823.00	Spring Housing	1
35	07824.00	Pinion	1
36	15130.00	6 x 6 x 36mm Key	1
37	08637.00	6006ZZ Bearing	2
38	15131.00	Spindle Flange	1
39	15132.00	Collar	1
40	15107.00	4-0.7 x 4mm Set Screw	1
41	STD851006	6mm Flat Washer*	3
42	16425.00	3-0.5 x 20mm Socket Head Bolt	2
43	15133.00	Sensor	1
44	15172.00	Head Locking Handle	1
45	15173.00	Bushing	1
46	15170.00	Bushing	1
47	16310.00	1/2-12 x 3 1/2" Hex Head Bolt	1

* Standard hardware item available locally.

Δ Not Shown

Recommended Accessories		
Δ	Sanding Drum Kit.	9-25262
Δ	4" Angle Vise	9-24085
Δ	4" Drill Press Vise	9-24093
Δ	4" Standard Vise	9-24073
Δ	4" Quick Grip Vise	9-24081
Δ	6" Standard Vise	9-24075
Δ	6" Drill Press Vise	9-24095
Δ	6" Cross Vise	9-24089
Δ	69-Piece Clamping Kit	9-26426

Model 351.229350

Figure 7 - Replacement Parts Illustration for Base and Table

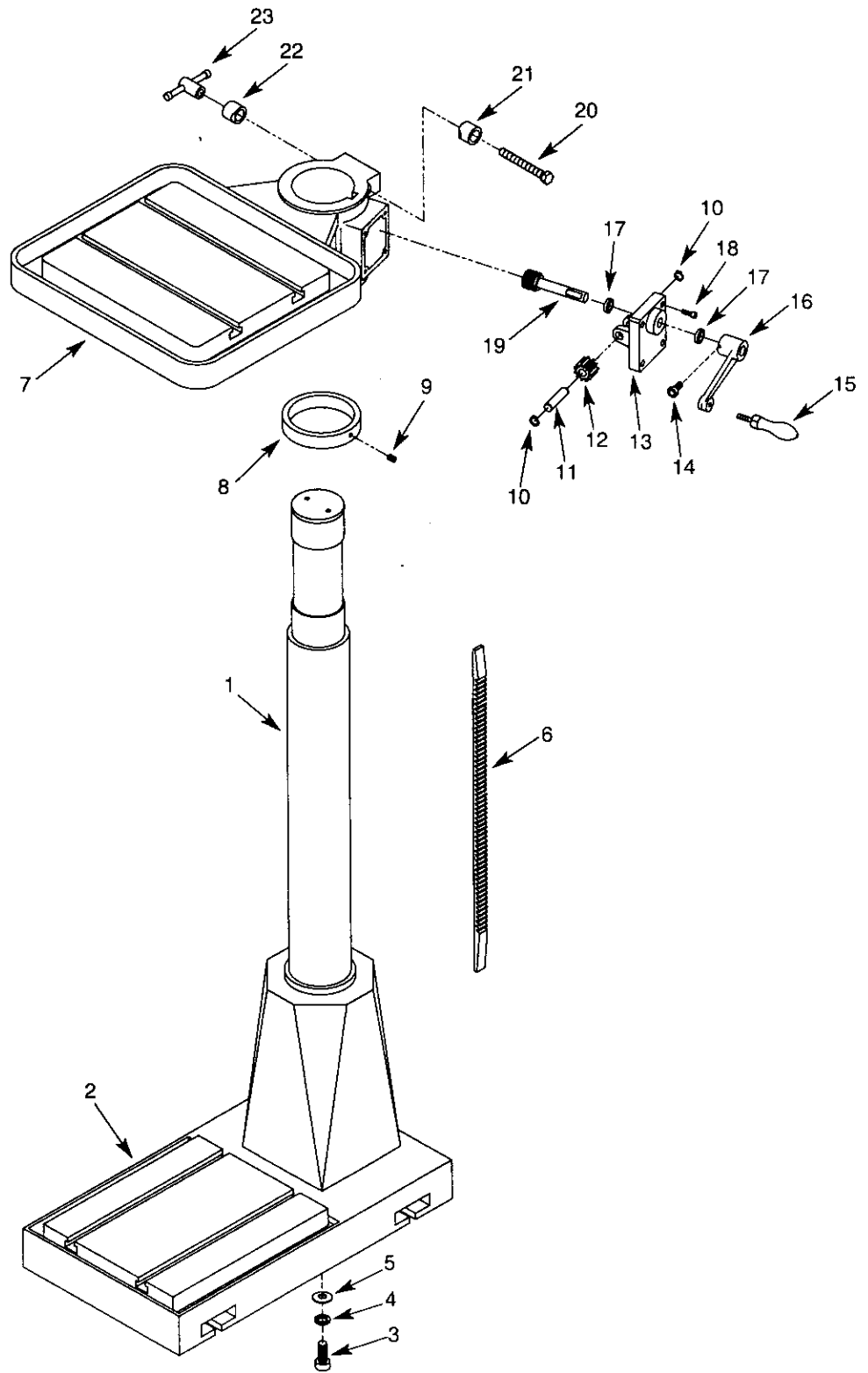

REPLACEMENT PARTS LIST FOR GUARD

KEY NO.	PART NO.	DESCRIPTION	QTY.
1	15134.00	Column Assembly	1
2	15161.00	Base	1
3	16311.00	12-1.75 x 25mm Socket Head Bolt	4
4	STD852012	12mm Lock Washer*	4
5	STD851012	12mm Flat Washer*	4
6	15136.00	Rack	1
7	15163.00	Table	1
8	15164.00	Collar	1
9	00351.00	6-1.0 x 10mm Set Screw	1
10	05989.00	3AMI-14 Retaining Ring	2
11	15165.00	Shaft	1
12	15166.00	Worm Gear	1
13	15167.00	Cover	1
14	01393.00	1/4-20 x 1/2" Socket Head Bolt	1
15	05811.00	Handle	1
16	07812.01	Crank Arm	1
17	15168.00	Bushing	2
18	00179.00	6-1.0 x 20mm Socket Head Bolt	4
19	15169.00	Worm Shaft	1
20	16310.00	1/2-12 x 3 1/2" Hex Head Bolt	1
21	15170.00	Bushing	1
22	15173.00	Bushing	1
23	15172.00	Table Locking Handle	1

* Standard hardware item available locally.

**In U.S.A. or Canada
for in-home major brand repair service:**

Call 24 hours a day, 7 days a week

1-800-4-MY-HOMESM (1-800-469-4663)

Para pedir servicio de reparación a domicilio – 1-800-676-5811

Au Canada pour tout le service – 1-877-LE-FOYERSM (1-877-533-6937)

For the repair or replacement parts you need:

Call 6 a.m. – 11 p.m. CST, 7 days a week

PartsDirectSM

1-800-366-PART (1-800-366-7278)

www.sears.com/partsdirect

Para ordenar piezas con entrega a domicilio – 1-800-659-7084

For the location of a Sears Service Center in your area:

Call 24 hours a day, 7 days a week

1-800-488-1222

To purchase or inquire about a Sears Maintenance Agreement:

Call 7 a.m. – 5 p.m. CST, Monday – Saturday

1-800-827-6655

